

DIAMOND STEELTRACK®



RT-VERSION

2957210



SC/HD-VERSION

2957220

Instruction manual

for all Baader Diamond Steeltrack® (BDS) Focusers



NT-VERSION

2957230



BAADER PLANETARIUM

Zur Sternwarte • D-82291 Mammendorf • Tel. +49 (0) 8145 / 8089-0 • Fax +49 (0) 8145 / 8089-105
Baader-Planetarium.de • kontakt@baader-planetarium.de • Celestron-Deutschland.de



Dear Customer,

Thank you for the purchase of a Baader Diamond Steeltrack® (BDS) Focuser. In this manual (valid for all three BDS-Versions) we explain the functions of these high-quality focusers. Please read the instructions carefully. Wrong handling may void the warranty.

Technical Data for all BDS focusers

BDS-SC and Skyris

Drive System:

- True diamonds form a micro-gear high precision drive system never accomplished before
- In comparison to conventional crayford or rack & pinion drives, this micro-gear movement has zero backlash, zero cogging, and zero flexure
- Diamond Steeltrack® 2" focusers lift a payload of 6 kg (13 lbs) straight up, without slipping and without excessive bearing preload (bearing preload can be increased further if necessary)
- Bearing system utilizes unbreakable Instrument Grade Roller-Bearings instead of simpler Ball Bearings – handles higher loads with greater rigidity and accuracy. No Teflon-pads anywhere
- 1:10 Stainless Steel fine-focus mechanism, ready for attachment of the optional Diamond Steeldrive temperature-compensating motor drive system
- Detachable drive block assembly is reversible for right hand or left hand fine-focus operation and for attaching the Diamond Steeldrive motor block
- Shortest possible mechanical design achieves optimum balance between focuser height (backfocus) and rigidity requirements
- Zero shift locking knob to precisely stop any movement without affecting optical axis adjustment



Imaging with BDS-RT, BBHS Mirror and Morpheus 76°

Focusing Drawtube:

- Each bearing individually adjustable for precise alignment of mechanical vs. optical axis
- Ultra-hard subzero coated bearing races – precision milled and much harder than anodizing or stainless steel
- Oversized 55mm inner clear diameter, to prevent vignetting, with anti-reflection knife-edge baffles



BDS Diamond pressure plate

Clamping System:

- S58 Dovetail ring-clamp built into focusing tube for accepting optional T-2 / M48 / M68 and other S58 direct-thread adapters to enable direct thread connection of accessories and cameras without 2" clamp
- 2" eyepiece clamp with hardened bronze clamp ring (length of clamp: 12.5 mm / 1/2") included as standard
- Optionally available: 2" Baader S58 Clicklock-clamp (# 2956258) w. integrated S58 dovetail (added length: 16 mm / 5/8 inch)
- Two auxiliary threads (M60x1 and M55x0,75) cut into the RT & NT focusing-tube for attachment of dedicated field flatteners or focal reducers/correctors



BDS-NT with Pushfix Adapter

Table of Contents

Technical Data for all BDS	2
BDS-RT: Scope of Supply & Dimensions	4
BDS-SC: Scope of Supply & Dimensions	6
BDS-NT: Scope of Supply & Dimensions	8
All BDS: Drive block	10
Switch left-hand / right hand	11
Adjusting drawtube to optical axis	12
BDS-RT: Accessory mounting.....	14
Optional Diamond Steeldrive	15
Maintenance, Warranty and Disclaimer.....	16

BDS-RT (# 2957210 | 80 mm focus travel)

Baader Diamond Steeltrack® for Refractors



Features

1. M68 x 1a telescope adapter
2. Ø 88 x 7 mm dovetail to adapt various telescope adapters. To access, M68 telescope adapter must be removed by loosening 6 x M5 screws
3. Integrated 2" standard clamp
4. 6 x M2,5 headless setscrews. Loosen with included 1.3 mm Allen wrench to detach the integrated 2" standard clamp, and to mount the alternative 2" BDS S58 Clicklock Clamp (#2956258), respectively T-2, M48 or M68 adapters (#2957202, -04, -06)
5. 5 x M5 screws for M5 threads to mount accessories (see page 14)
6. Adjustment screws: 4x headless setscrews, 2x rounded cap screws (instructions see page 12/13)
7. Engraved index scale: 0 – 80 mm, 1 mm steps

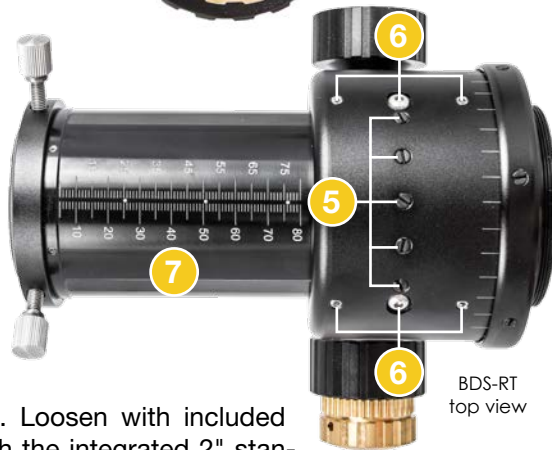

BDS-RT: Dimensions

All measurements in mm

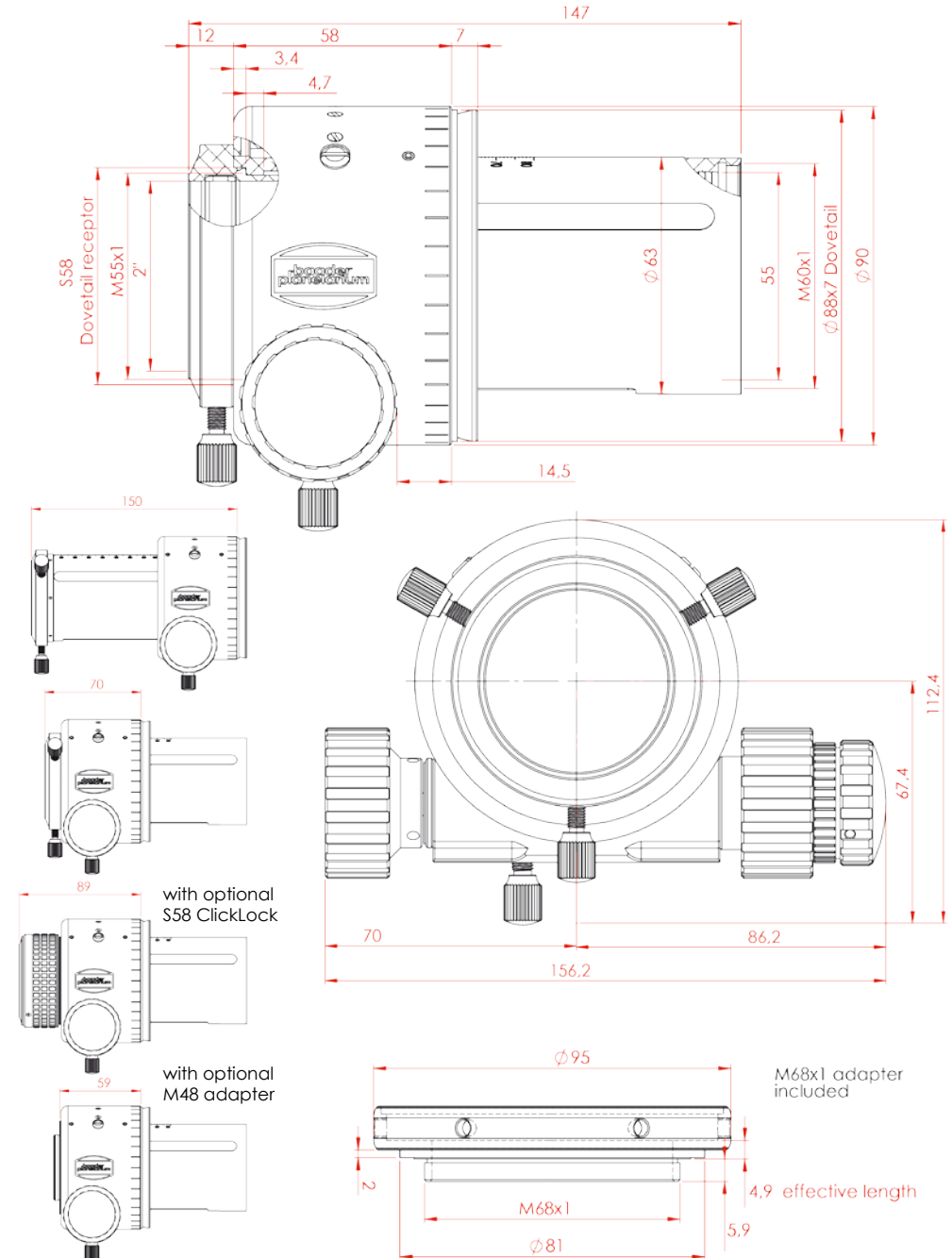

BDS-SC/HD (# 2957220 | 30 mm focus travel)

Baader Diamond Steeltrack® for Schmidt-Cassegrains



Features

1. Adapter for mounting onto 2" UNF threads such as Celestron SC/HD or Meade telescopes
2. Adapter for mounting onto Celestron 3,3" threads such as Celestron C11 / C14 telescope. *To access the thread, adapter #1 has to be removed*
3. Ø 88 x 6 mm dovetail to adapt various telescope adapters. *To access, remove 2"/3.3" adapter by loosening 6 x M5 screws*
4. Integrated 2" standard clamp
5. 6 x M2,5 headless setscrews. Loosen with included 1.3 mm Allen wrench to detach the integrated 2" standard clamp, and to mount the alternative 2" BDS S58 Clicklock Clamp (#2956258), respectively T-2, M48 or M68 adapters (#2957202, -04, -06)
6. Adjustment screws: 4x headless set screws, 2x rounded cap screws (instructions see page 12/13)
7. Engraved index scale: 0 – 30 mm, 1 mm steps



BDS-SC/HD: Dimensions

All measurements in mm

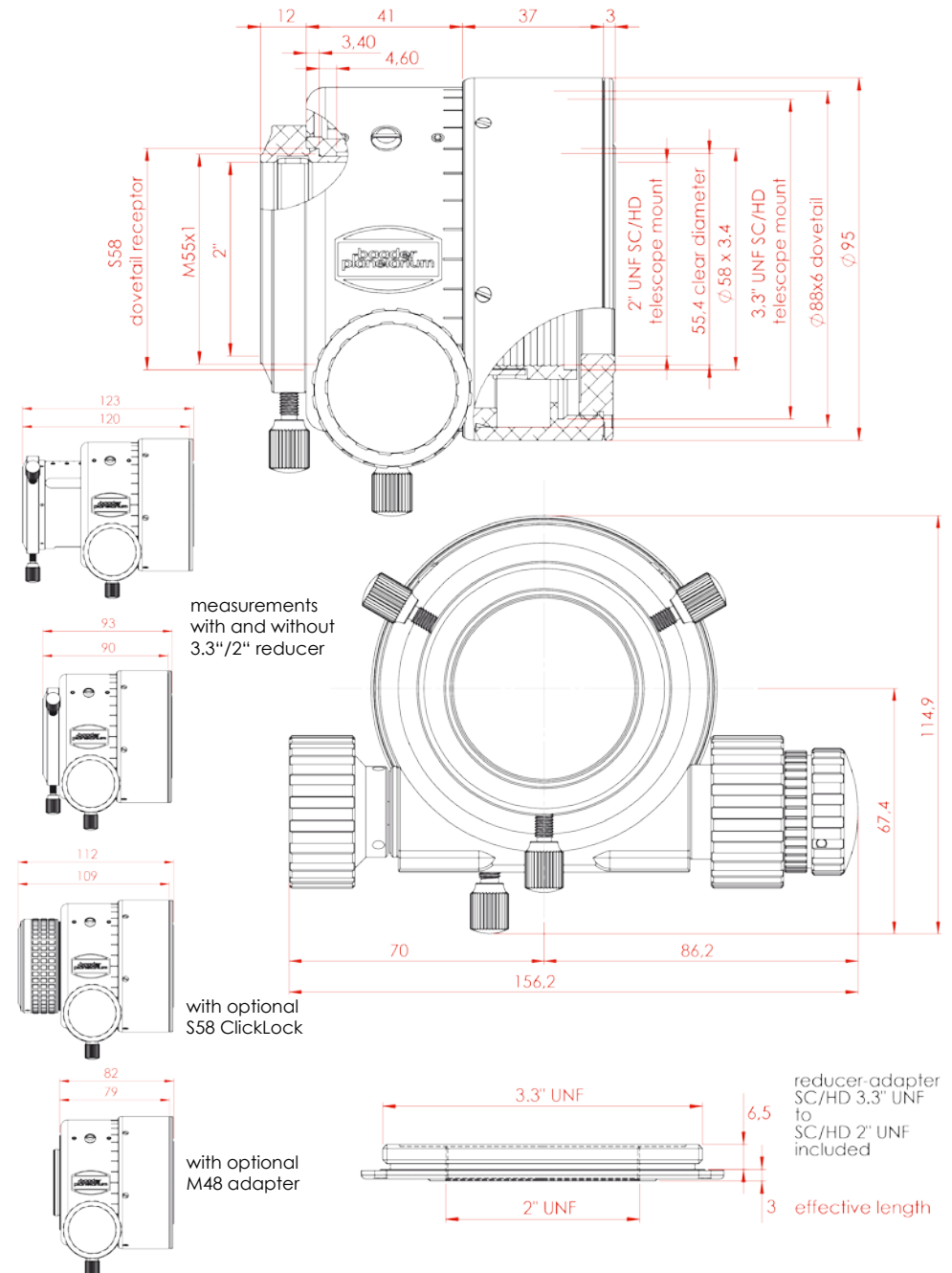

BDS-NT (# 2957230 | 40 mm focus travel)

Baader Diamond Steeltrack® for Newtonian telescopes



BDS-NT side view

Features

1. Baader VersaBase for perfect fit onto most tube diameters ($\geq 200\text{mm } \varnothing$)
2. Square POM-washers with radius
3. 2x 1.5mm strip-shims (Spacers) – can be added or removed depending on tube diameter.
4. Radial V2A sliding bolts
5. $\varnothing 88 \times 5 \text{ mm}$ dovetail to adapt various telescope adapters. *To access, VersaBase must be removed by loosening screws (see #9)*
6. Integrated 2" standard clamp
7. 6 x M2,5 headless setscrews. Loosen with included 1.3 mm Allen awrench to detach the integrated 2" standard clamp, and to mount the alternative 2" BDS S58 Clicklock Clamp (#2956258), respectively T-2, M48 or M68 adapters (#2957202, -04, -06)
8. Recessed area allows the use of very short 1 1/4" reducers, e.g. Baader Pushfix adapter (#2408151) with 1mm optical height
9. Focuser can be removed and/or rotated on VersaBase by loosening 8x hex screws M4 (two screws on each side)
10. Adjustment screws: 4x headless set screws, 2x rounded cap screws (instructions see page 12/13)
11. Engraved index scale: 0 – 40 mm, 1 mm steps



BDS-NT top view

BDS-NT: Dimensions

All measurements in mm

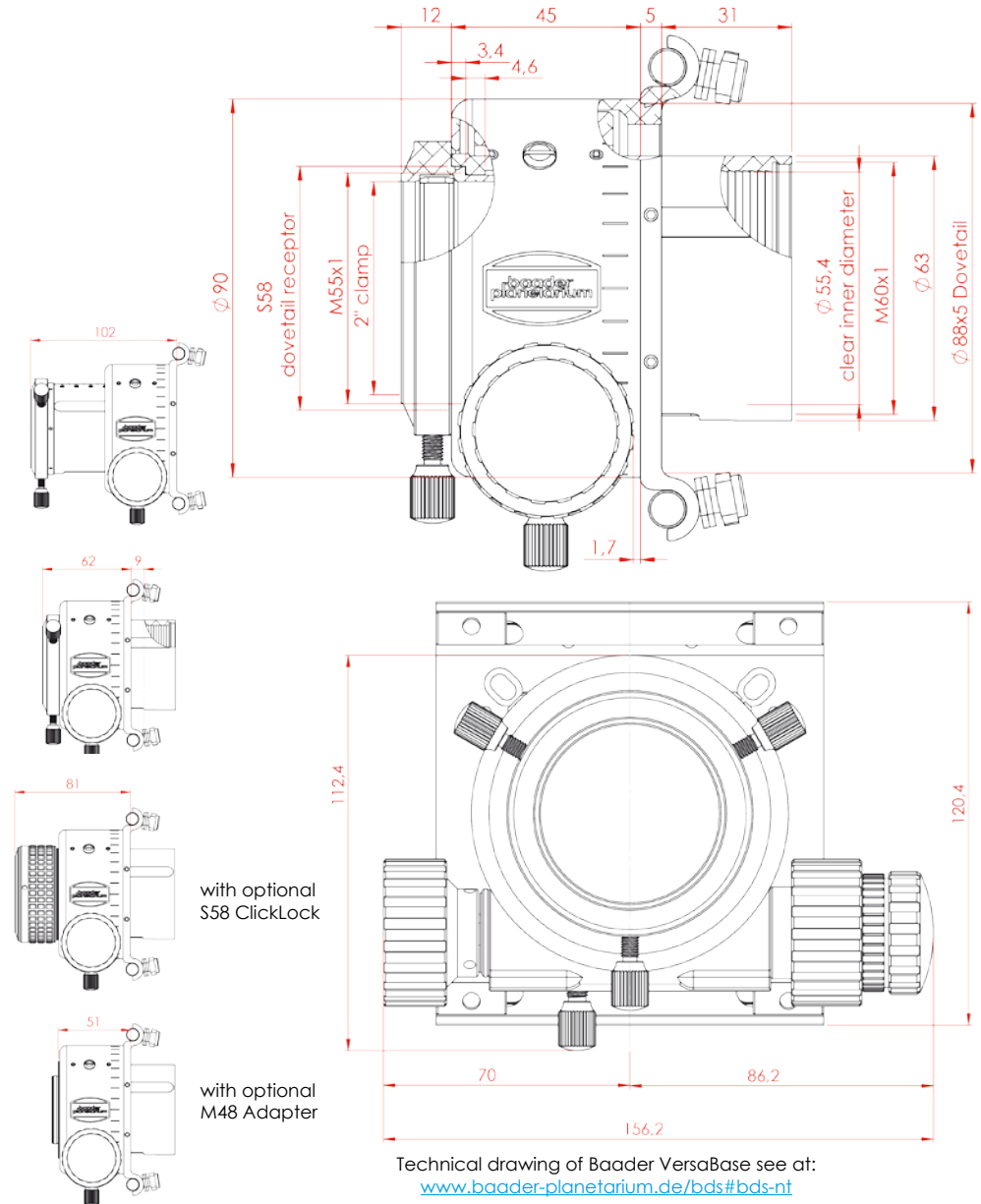

Technical drawing of Baader VersaBase see at:
www.baader-planetarium.de/bds#bds-nt



BDS-NT mounting instructions in 9 steps:
www.youtube.com/watch?v=6_51YPcFPvQ



Diamond Steeltrack® drive block (Example: BDS-RT Diamond Steeltrack®)

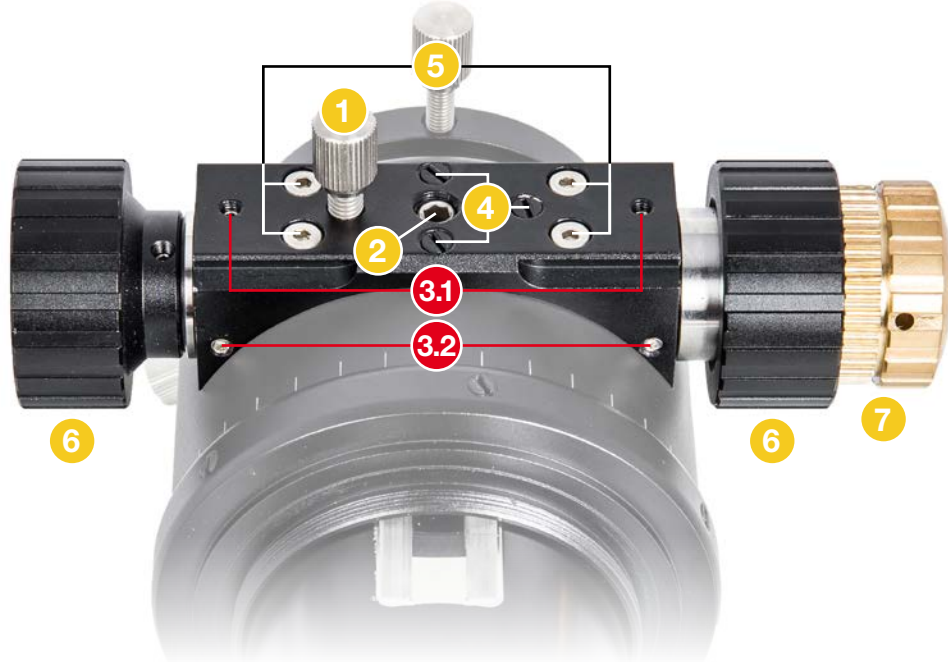

1. **Tension break:** This screw works as break for the diamond-coated drive axis. There is a rotary-bearing mounted brake-pad between drive axis and screw. This way, no pressure is applied onto the steel-plate which might otherwise cause tipping when the screw is tightened. **BDS are rigid and slip-proof; they don't need a locking screw which presses onto tube or drive plate.** Because of this construction motor focusers can be used any time, without risking tipping of the image plane.
2. **Pressure screw:** Adjusts the contact pressure between the diamond-coated axis and the steel-plate. By factory default, it holds up to 6 kg lifting force. You can tighten it further, but then the focuser will not run as smoothly. This 6-kg-setting was chosen for photographic use. You can untighten it for visual use to make the focuser even more smooth-running.
3. **Screws for factory-setting of the optical axis. You should not change these settings. For further information see page 12/13**
4. **M6 sealing screws:** These screws have no function; you can remove them to attach additional accessories.
5. **Attachment screws** connecting the reduction gear unit with the BDS-body. To switch left/right-hand use, see page 11
6. **Coarse focuser:** One turn equals approx. 22 mm of movement
7. **Fine focuser:** One turn equals approx. 2 mm of movement

Changing drive block for left-hand use (Example: BDS-RT Diamond Steeltrack®)

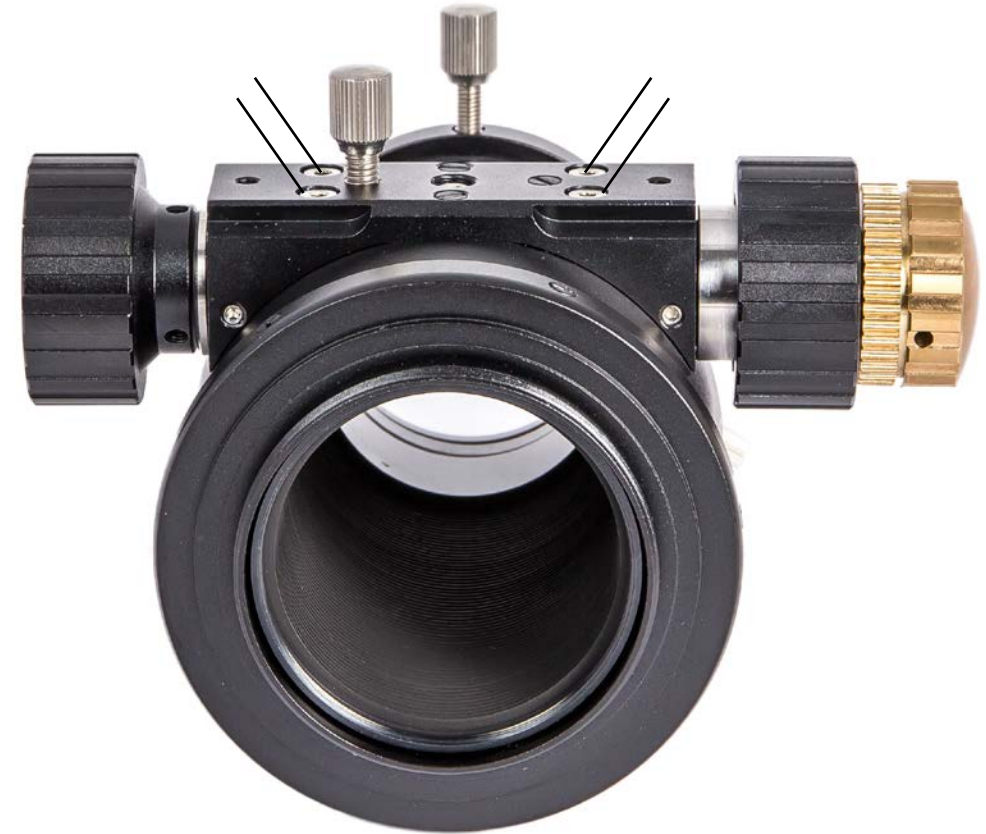

Lay the focuser horizontally on a flat table. Open and remove only the four marked screws (see also #5 on page 10) with a 2.5 mm metric Allen wrench.

Now lift the whole drive block assembly gently. Make sure that the focuser doesn't slip away. Rotate the drive block by 180° and put it carefully back in place. Then put the screws back in place and tighten them carefully with the long side of the Allen wrench using only two fingers. Extensive force on the screws may destroy the threads. Afterwards check the alignment and if the focuser runs as smooth as before.

For Dos and Don'ts, please see also alignment instructions (page 12/13)

All BDS: adjusting the drawtube to align with the optical axis of your telescope

Baader Diamond Steeltrack® (BDS) focusers are unique in their ability to be fine-aligned (collimated), enabling critical users to achieve accurate alignment, or 'squaring-on' of the focuser to the optical axis. This is particularly useful for imagers who require the imaging plane to be accurately square to the optical axis in order to produce sharp stars out to all corners of their images. Critical users of SCT telescopes will also find this alignment capability useful, to give them the necessary degree of freedom to finally achieve accurate alignment of the focuser axis to the optical axis (alignment of the focuser axis to the center of the secondary mirror).

Every BDS focuser is perfectly precision aligned at our factory to be square to its mounting base. Most users will find that this nominal alignment is sufficient to give very good performance with most commercially produced telescopes and that adjustment of the focuser alignment is not needed or desired. This is particularly the case for visual observers, where precise squaring-on of an eyepiece is not needed nor even detectable.

Warning, please note:

- The following adjustment procedure is provided for those users who require an accurate alignment ('squaring-on') of the focuser to the optical axis. We do not recommend it for most visual uses.
- Before attempting any adjustment, we recommend that you first read through these instructions completely in order to familiarize yourself with the process.
- Adjusting a focuser can be very tricky. We recommend always making only small adjustments / turning screws by a small amount in order to be able to gradually home in on the perfect setting. Too large adjustments will give rise to a result that is uncontrollable.
- Right at the beginning of the procedure, you should first take note of the force required to pull out the focuser tube against the existing contact pressure. This force should not be substantially exceeded to avoid damaging the mechanism.
- During the first adjustment procedure, no heavy accessories should be attached – the focuser tube is loose and could slip out. Once you are familiar with the procedure and you know how the focuser behaves you can dare to leave your camera on the focuser while adjusting. Please note that Baader Planetarium will not be held responsible for damages to your equipment due to slipping of the drawtube.
- All BDS focusers have been designed so strong to carry heaviest loads without danger to any of the components. We are convinced that any damage done to bearings or drive mechanism represents a clear sign of improper handling. In general screws should never be tightened too firmly as mechanical parts, such as bearings, could be subjected to high loads and thereby destroyed. Such treatment may void the warranty and result in costly repairs.

Please read the following thoroughly and only proceed with the alignment procedure if you feel well informed about what you are doing.

Tools Required:

1. Metric Hex Keys (2mm, 2.5mm, 4mm)
2. Collimation Tool: We recommend the use of a collimation tool to monitor changes in focuser adjustment and to attain accurate alignment of the focuser axis to the optical axis. A laser collimator such as the Baader Mark III LaserColli™ (#2450343) is ideal for this purpose (RT/NT only).

Adjustment procedure:

Screws marked No.8 are holding the bearing block in place which fastens all four roller-bearings. These two screws are the pivot point for the bearing block. Screws no. 6-9 are the bearing adjustment screws we are aiming at for this instruction. The focuser is set to a certain pressure. Tightening down the adjustment screws will increase the pressure even more. So before you tighten something you always must at first release pressure at the other side (*means: when you for instance tighten screws 5+7 or 4+6 at the same time, you must first release the screw 8 at the same side*).



Up and Down

A: Shifting the drawtube up on the CCD side and down on the telescope side:

- Loosen screws 4 and 5 by ½ turn
- Tighten screws 6 and 7 by ½ turn

B: Shifting the drawtube down on the CCD side and up on the telescope side.

- Loosen screws 6 and 7 by ½ turn
- Tighten screws 4 and 5 by ½ turn

Sideways

(This is not very handy to do as the up and down position will always simultaneously change slightly. Only VERY slight changes should be made)

C: Shifting the drawtube sideways to the left

- Loosen screws 4 and 7 by ¼ turn
- Tighten screws 5 and 6 by ¼ turn

D: Shifting the drawtube sideways to the right

- Loosen screws 5 and 6 by ¼ turn
- Tighten screws 4 and 7 by ¼ turn

More adjustment typically is not necessary. We recommend not to change the factory centering. Nevertheless it is possible (as shown below). If you feel comfortable with what you are doing, you can change the entire center position of the drawtube which we had set as factory setting. This may only become necessary if your lens is not perfectly centered with your mechanics to a large degree. Centering can be checked by putting a star in the center of your chip and rotating the focuser. If the star circles on the chip your focuser is not fully centered to the lens. You may be able to tilt the lens with the tip tilt screws. However, many scopes do not offer this possibility. Therefore the BDS offers to displace the entire drawtube to a very small degree, for finding the new optical/mechanical centerline. You should make small iterative adjustments rather than doing one BIG change and ruin the hole adjustment beyond return. Carefully watch out to not have the drawtube scratch against the outer housing.



Lifting/Lowering drawtube in parallel to the focuser housing

E: Lifting the whole drawtube up

- Loosen screws 4-7 as well as 3.2 by ½ turn
- Tighten screws 3.1 by ½ turn as well as screws 2 and 1 by ¼ turn, then fasten screws 8 and 3.2 hand tight

Then check if every screw except 1 is tight and fasten it hand tight if necessary. Check the lifting force and adjust screw 2 until the payload does not slip if in vertical position.

F: Lowering the whole drawtube down

- Loosen screws 8, 3.1 and 3.2 by ½ turn as well as screws 2 and 1 by ¼ turn
- Tighten screws 4-7 by ½ turn, then fasten all other screws except 1 hand tight

Then check if every screw except 1 is tight and fasten it hand tight if necessary. Check the lifting force and adjust screw 2 until the payload does not slip if in vertical position.

In case the optimum adjustment has not yet been achieved, you should repeat the procedure. After a short time, you will develop a feel for the interaction of the various adjusting screws. In each case, make sure not to continue increasing the pressure in the same direction without relieving it in the opposite direction accordingly, in order to avoid damage to the mechanics.

Only for BDS-RT

Baader Standard Base and further accessories

To mount the Baader Standard Base, remove two of the 5 x M5 screws (see also #3 on page 4). These screws serve only to cover the M5 threads that have been drilled in the BDS-RT housing to allow attachment of further accessories.



All BDS: Diamond Steeldrive motor drive (Example: BDS-SC Diamond Steeltrack®)

All Baader Diamond Steeltrack® focusers are equipped with a dovetail which allows the mounting of the optional Baader Diamond Steeldrive temperature compensating motor drive system (# 2957152). A mounting instruction is included with each Diamond Steeldrive.



Maintenance

Baader Diamond Steeltrack® focusers require very little maintenance.

The focusers should be kept clean to prevent dust and dirt to accumulate on the tracks. If the tracks are found to be dirty, clean with a soft cloth and isopropyl alcohol.

The focuser should not be subjected to temperatures > 80° C (176° F). This is the max. temperature for the grease specification used.

The Baader Diamond Steeltrack® is greased for lifetime. No re-greasing is necessary. Please note: do not apply any grease onto the roller track or onto the Diamond pressure plate.

Product care

After years of intensive use, the lubricating grease may solidify. However, even solidified grease will not have any significant affect on the function of the system.

The color anodizing of the Baader Diamond Steeltrack® is as resistant to aging as possible using state-of-the-art methods of electro-plating. The color, nevertheless, may change slightly if it is exposed to UV-radiation for years. UV-radiation is exceptionally intense if for example the focuser is positioned behind a window directed south in the same setting for years.

Every shop that features a window display facing the sun experiences this effect. Leather shoes, textiles, etc. fade within a short period of time – anodized metallic surfaces suffer the same effect. For this reason, most shop windows are fitted with UV-absorbing film, to prevent the displayed goods from fading within a short while. Few private household windows incorporate UV protection and we recommend that you protect the Baader Diamond Steeltrack® from prolonged exposure to UV.

Warranty and Re-Alignment / Repairs

Attempting to tweak the alignment of your BDS-focuser in regard to the optical axis of the telescope with brute force or by not following the instructions on page 12 may void the warranty. We certainly will be able to repair your Diamond Steeltrack®, but we may have to charge you for the repair.

© Baader Planetarium 2015. All Rights reserved. Products or instructions may change without notice or obligation. Images and illustrations may differ slightly from the original products. We reserve the right of errors. Reproduction of this instruction manual, complete or in parts, only with written permission by



BAADER PLANETARIUM G
M
B
H

Zur Sternwarte • D-82291 Mammendorf • Tel. +49 (0) 8145 / 8089-0 • Fax +49 (0) 8145 / 8089-105
Baader-Planetarium.de • kontakt@baader-planetarium.de • Celestron-Deutschland.de